



SILVERSTONE[®]
Designing Inspiration

SFX Form Factor SST-SX650-G SST-SX500-G

The standard SFX power supply benchmark

Support standard SFX form factor

Silent running 92mm fan with 18 dBA minimum

All Japanese capacitors

High efficiency with 80 PLUS Gold certification

Class-leading single +12V rail

Strict $\pm 3\%$ voltage regulation and low ripple & noise

100% modular cables

All cables made with flexible flat arrays

SPECIFICATION

SFX Form Factor

SST-SX650-G

SST-SX500-G

650W, 500W Switching Power Supply With Active PFC 80Plus Gold

1.General

1.1 Scope

This specification defines the performance characteristics of a single phase 650 watts, 500 watts, 5 output power supply. This specification also defines worldwide safety and electromagnetic compatibility requirements for the power supply which is intended for use in computer products.

2.Input Characteristics

2.1 Input Voltage

Nominal Voltage
100-240 Vrms

Voltage Variation Range
90 - 264 Vrms

2.2 Input Frequency

Nominal Frequency
50-60Hz

Frequency Variation Range
47 Hz to 63 Hz

* The power supply must operate at above frequency with 90 - 264VACrms input voltage range.

2.3 Max. Input AC Current

Max. Input Current
10.0A

Measuring Range
90 - 264Vrms

2.4 Inrush Current

The power supply must meet inrush requirements for any rated AC voltage, during turn on at any phase of AC voltage, during a single cycle AC dropout condition, during repetitive ON/OFF cycling of AC, and over the specified temperature range. The peak inrush current shall be less than the ratings of its critical components (including input fuse, bulk rectifiers, and surge limiting device).

2.5 Efficiency

SX650-G, SX500-G provides an efficiency of 87% at20% load, 90% at50% load, 87% at100% load under115V/60Hz and 230V/50Hz condition.

3. Output characteristics

3.1 Normal Operation Output

SX650-G

Output Voltage	Load MIN	Range MAX	Peak	Regulation	Ripple P-P Max.	Ripple & Noise P-P Max.
1. +5V	0A	22A		±3%	50mV	50mV
2. +3.3V	0A	22A		±3%	50mV	50mV
3. +12V	0A	54.2A		±3%	120mV	120mV
5. -12V	0A	0.3A		±10%	120mV	120mV
6. +5Vsb	0A	2.5A		±5%	50mV	50mV

- Maximum continuous total DC output power should not exceed 650W.
- Maximum continuous combined load on +3.3VDC and +5VDC outputs shall not exceed 110W.
- Maximum combined load on 12V outputs shall not exceed 650W.

NOTE:

Noise test should be measured with 20 MHz bandwidth frequency oscilloscope. The output terminal shall add a tantalum capacitor of 10uF in parallel with a ceramic capacitor of 0.1uF.

SX500-G

Output Voltage	Load MIN	Range MAX	Peak	Regulation	Ripple P-P Max.	Ripple & Noise P-P Max.
1. +5V	0A	22A		±3%	50mV	50mV
2. +3.3V	0A	22A		±3%	50mV	50mV
3. +12V	0A	41.7A		±3%	120mV	120mV
5. -12V	0A	0.3A		±10%	120mV	120mV
6. +5Vsb	0A	2.5A		±5%	50mV	50mV

- Maximum continuous total DC output power should not exceed 500W.
- Maximum continuous combined load on +3.3VDC and +5VDC outputs shall not exceed 110W.
- Maximum combined load on 12V outputs shall not exceed 500W.

NOTE:

Noise test should be measured with 20 MHz bandwidth frequency oscilloscope. The output terminal shall add a tantalum capacitor of 10uF in parallel with a ceramic capacitor of 0.1uF.

3.2 Remote On/Off Controlled mode

The PSON# signal is required to remotely turn on/off the power supply, PSON# is an active low signal that turns on the output power rails. When this is not pulled low by the system, or left open, the outputs (except the +5VSB) turn off. This signal is pulled to a standby voltage by a pull-up resistor internal to the power supply.

TTL level "H" 2.0 V - 5.25 V
"L" 0.0 V - 1.0 V

3.3 Regulation

The cross regulation defined as follows, the output regulation should be within the specified range.

SX650-G

Loading	+5V	+3.3V	+12V	-12V	+5Vsb	Pout
20%	2.22A	2.22A	9.07A	0.05A	0.42A	130.0 W
50%	5.55A	5.55A	22.68A	0.13A	1.05A	325.0 W
100%	11.10A	11.10A	45.37A	0.25A	2.09A	650.0 W

SX500-G

Loading	+5V	+3.3V	+12V	-12V	+5Vsb	Pout
20%	2.12A	2.12A	6.65A	0.05A	0.40A	100.0 W
50%	5.29A	5.29A	16.64A	0.12A	1.00A	250.0 W
100%	10.58A	10.58A	33.27A	0.24A	2.00A	500.0W

3.4 Rise Time

DC output rise time is less than 20 mS at nominal line and full load.

3.5 Hold-up Time

PG output maintains at least 16mS is 100% 1oad after power off which hold within para 3.1 under 115V/60Hz and 230V/50Hz condition.

3.6 5VSB

5VSB is required for the implementation of PS-ON described above. 5VSB is a standby voltage that may be used to power circuits that require power input during the powered-down state of all power rails. The 5 VSB pin should deliver 5V \pm 5% at a minimum of 2.5A for PC board circuits to operate. Conversely, PC board should draw no more than 2.5A maximum from this pin. This power may be used to operate circuits such as soft power

3.7 PG-OK

PG-OK is a power good signal and should be asserted high by power supply to indicate that the +5 VDC and +3.3 VDC outputs are above the under-voltage thresholds of the power supply. When this signal is asserted high, there should be sufficient mains energy stored by the converter to guarantee continuous power operation within specification. Conversely, when either the +5VDC or the +3.3VDC output voltage falls below the under-voltage threshold, or when mains power has been removed for a time sufficiently long so that power supply operation is no longer guaranteed, PG-OK should be deasserted to a low state. See Figure 1 for a representation of the timing characteristics of the PG-OK, PS-ON, and germane power rail signals.

3.8 3.3V Sense

A default 3.3V sense line should be implemented pin 13 of the connector.

3.9 Capacitive Load

The power supply should be able to power up and operate normally with the following capacitances simultaneously present on the DC outputs.

Output	Capacitive load (uF)
+5V	10,000
+12V	10,000
+3.3V	10,000
-12V	350
+5Vsb	10,000

4. Protection

4.1 Input Protection

In primary circuit of the power supply , a protected fuse is inserted. Only internal fault of the power supply will cause the fuse blown. Any overload or short circuit at DC output will keep from fuse brown or fire hazard.

4.2 Output Protection

4.2.1 Under voltage protection

The +5V/+3.3V DC output are protected against the under voltage condition. range value can't be exceed 3.3~3.7V at 5V terminal and 2.0~2.4V at 3.3V.

4.2.2 Over Voltage Protection

The +5V/+12V/+3.3V DC output are protected against the over voltage condition. Maximum value can't be over 6.5V at 5V terminal and 16.0V at 12V, 4.5V at 3.3V.

4.2.3 Over Power Protection

The power supply can be used electronic circuit to limit the output current against exceeding 50% of surge output power or protected against excessive power delivery since short circuit of any output or over total power at high line.

4.2.4 Short Circuit Protection

Short circuit placed on +5V,+12V,+3.3V,-12V will latch off. +5VSB will auto-recovery.

4.2.5 Over-Current Protection

Current protection should be designed to limit the current to operate within safe operating conditions. Over current protection schemes where only the voltage output that experiences the over current event is shut off may be adequate to maintain safe operation of the power supply and the system; however, damage to the motherboard or other system components may occur.

The recommended over current protection scheme is for the power supply to latch into the shutdown state. The setting of over current protection for each output rail is as following.

4.2.6 Over Temperature Protection

5. Start Stability

5.1 No Load Start

When power is applied to SX650-G, SX500-G with no load connected or under minimum load connected, neither damage to power supply nor hazards to users will occur.

5.2 Cold Start

The power supply shall operate properly when first applied at normal input voltage and or so maximum load after 4 hours storage in 0°C environment.

6. Environments

6.1 Temperature and Humidity

6.1.1 Operating

Temperature	0 to 40 °C
Relative Humidity	20 to 90 %

6.1.2 Storage

Temperature	-40 to 70 °C
Relative Humidity	20 to 95 % noncondensing

6.2 Altitude

The power supply can operate normally at any altitude between 0 to 10000 feet.

6.3 Vibration and Shock

Sweep and resonance search for each of X,Y,Z, axis at the sweep.

RATE of 1/OCTAVE/Min.

Frequency	Duration	Amplitude
5-55-10 Hz	30 minutes	0.35 mm

7. Conducted EMI

8. Product Safety

8.1 Safety Requirement

8.2 Leakage Current

The AC leakage current is less than 3.5mA when the power supply connect to 253Vac/50Hz .

8.3 Insulation Resistance

The insulation resistance should be not less than 30M ohm after applying of 500VDC for 1 minute.

8.4 Dielectric Voltage Withstand

The power supply shall withstand for 1 minute without breakdown the application of a 60Hz 1500V AC voltage applied between both input line and chassis (20mA DC cut-off current). Main transformer shall similarly withstand 3000Vac applied between both primary and secondary windings for a minimum of one minute.

9. Power Good Signal

A TTL compatible signal for the purpose of initiating an orderly start-up procedure under normal input operating conditions. During power up, this signal is asserted (low) until +5V is under regulation and AC reaches min. line specification range. After all voltage are going appropriate level, the system may have a turn on delay of 100mS, but no greater than 500mS. During power off the signal should go to low level before +5V is out of regulation. The low level is 0 to 0.8V and high level is 4.75 to 5.25V. The " Power Good "signal can drive up to 6 standard TTL loads.

Time Diagram

Figure 1

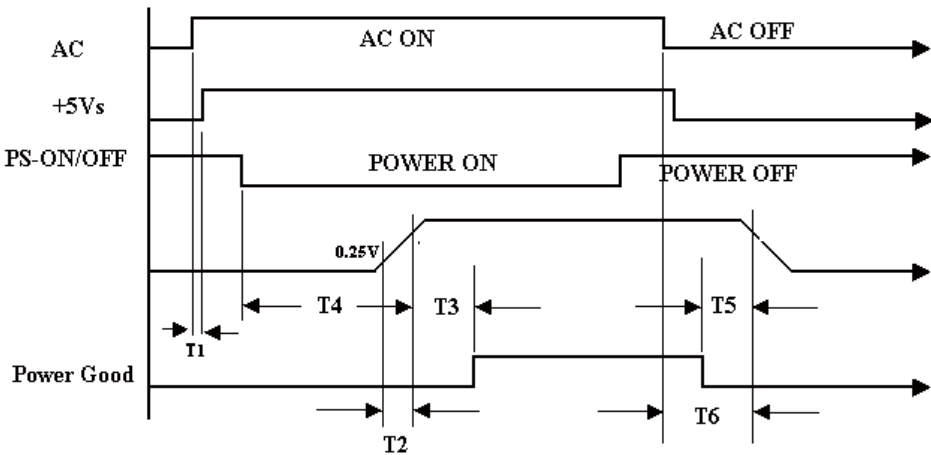

- * T1 : Turn on time (2 sec. Max.)
- * T2 : Rise time ($\leq 20\text{mS}$ Max.)
- * T3 : Power good turn on delay time ($100 < T3 < 500 \text{ mS}$)
- * T4 : Switch on time (0.5 sec. Max.)
- * T5 : Power good turn off delay time (1.0 mS Min.) AC/OFF
- * T6 : Power hold-up time (16 mS Min.at 100%load)
- * Power on-off cycle :

When the power supply is turned off for a minimum of 2.0 sec. and turn on again, the power good signal will be asserted.

10. MTBF

The MTBF of the power should be 100,000 hours min.

11. Burn-In

11.1 Input Voltage

Applying 230Vac

11.2 Test Condition

Applying 80% loads for the power supply in 40 (+/-5) oC chamber for 4 hours.

12. Harmonics

The product shall meet requirement for EN61000-3-2 & EN61000-3-3 :2003 standard of class D, test at 230Vac 50Hz.

13. Power Factor

The power supply with active power factor correction, and meet the EN61000-3-2 standards, The power factor is greater than 0.95 at 230V/50Hz, Max. load.

14. Mechanical Specification

14.1 Physical Dimension

125 mm (W) × 63.5 mm (H) × 100mm (D)

SilverStone Technology Co., Ltd.

www.silverstonetek.com

support@silverstonetek.com

NO. G11231700