

Quick installation Guide of RMS02

Installation Instructions

Stag -Beagle tool-less server slide, 180 pounds (80kg) loading.

4 STEPS TO THE SUCCESSFUL INSTALLATION!!

A. Please note that the 180lb-grade SB Tool-less is designed and built for 2U chassis or above. Not recommended for 1U applications.

B. The SB bracket is for EIA rail with hole pitch as shown on fig-1 and square holes, and can only be mounted behind the rail. You will need to purchase transfer bracket in order to mount SB bracket on the rail with round holes. The standard retail packaging shall include one piece of left hand, one piece of right hand, 4 pieces of H-370 screws for ear plate fastening and 2 pieces of H-315 screws for chassis fastening.

* The 180lb-grade SB tool-less is not designed to be screw mounted. You Must mount the slides with bayonet pre-formed on the chassis.

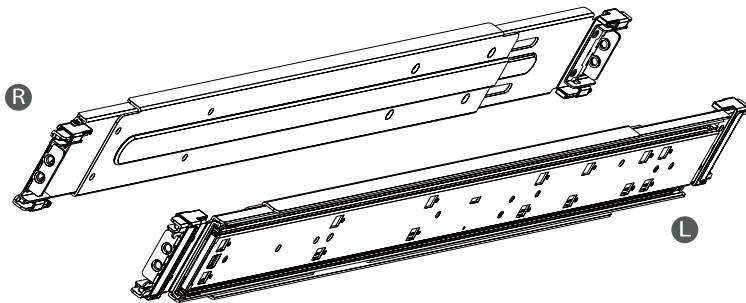

SCREW KIT

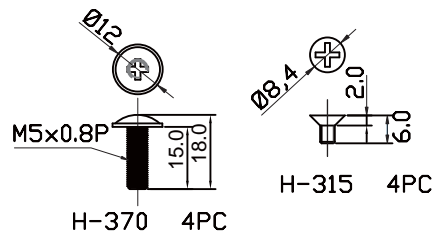

After installation or maintenance is finished, you may secure the server by putting screw through the center hole on bracket.

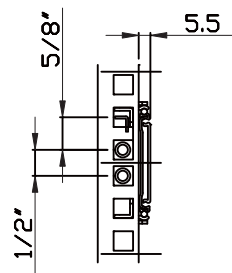

(Fig-1)

Step 1 > Remove the chassis (inner) member



Pull the slide open. Then press the trigger down as shown on the drawing, and pull the chassis (inner) member out.

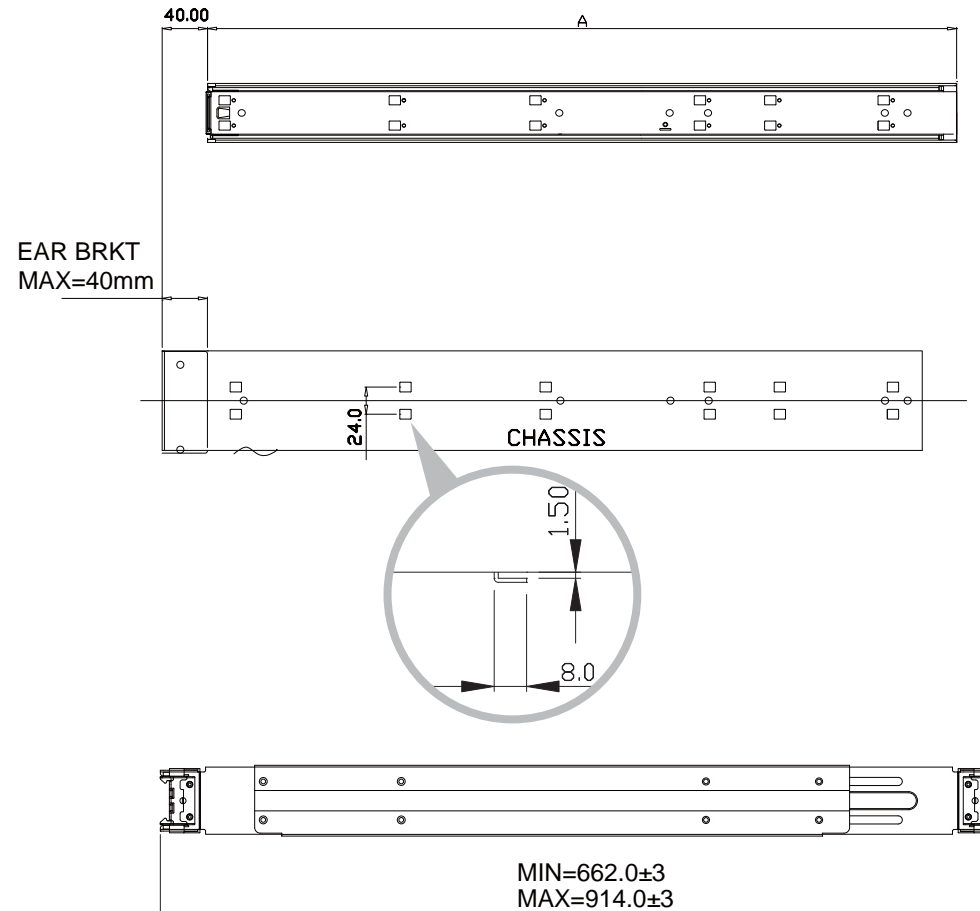
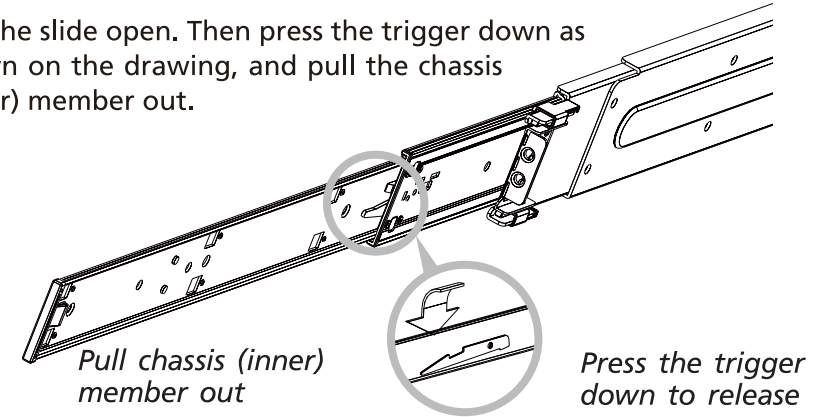

**Extendable front bracket only apply to some Tool-less model EXT=300MM

Step 2 > Mount the chassis (inner) member to the chassis

⬇ Please secure the screws on both sides and push back the inner member to allow the rail slide to be fixed to the rackmount chassis. Moreover, please make sure the spring clip installation has been completed on the rackmount chassis when finishing this step.

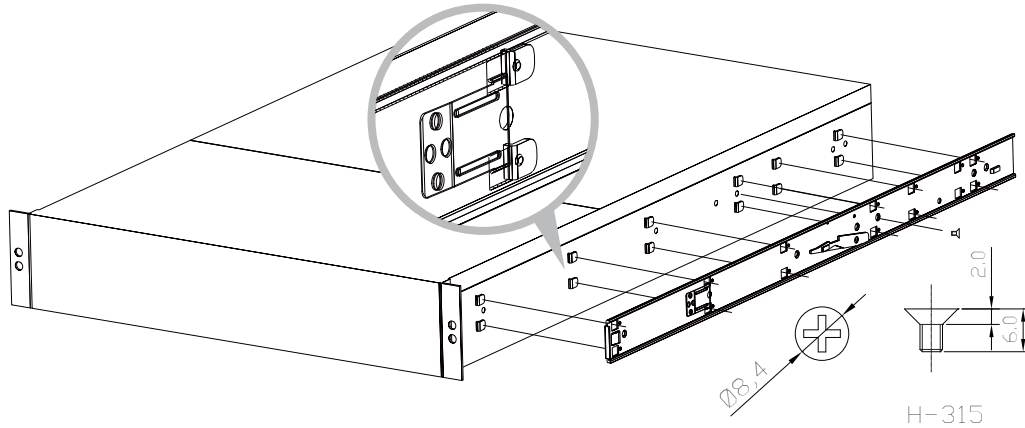

*Bayonet on chassis shall be pre-formed as per the recommended dimension and location.

*If you need to remove the inner member from the rackmount chassis, please pull up spring clip first and then push forward to allow the spring clip to separate from the inner member.

If you had already installed the screw in your rackmount chassis, please remove the screws first.

Step 3 > Attach the cabinet (outer) member to the rail

⬇ Insert the stag into the upper and lower square holes on EIA rail from the back of rail. Push the safety lock forward to secure the bracket. It is important to check if the safety lock is in unlocked position before mounting the brackets.

*Release safety lock before mounting

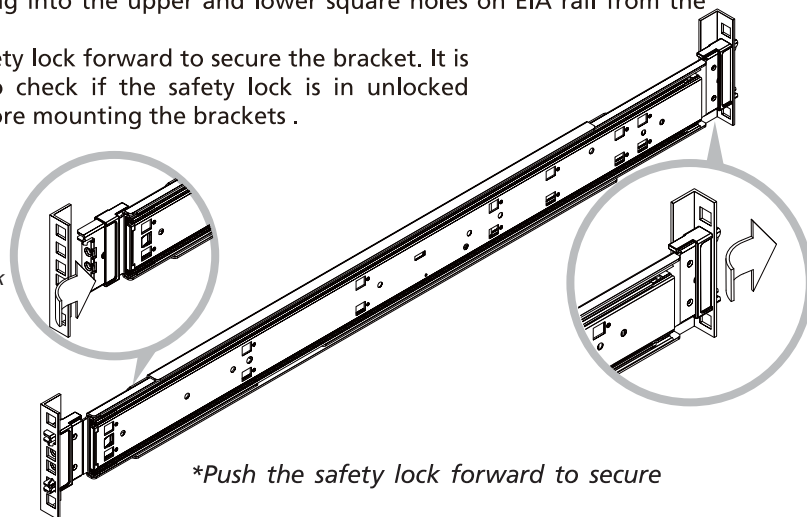

*Push the safety lock forward to secure

Uninstall the bracket

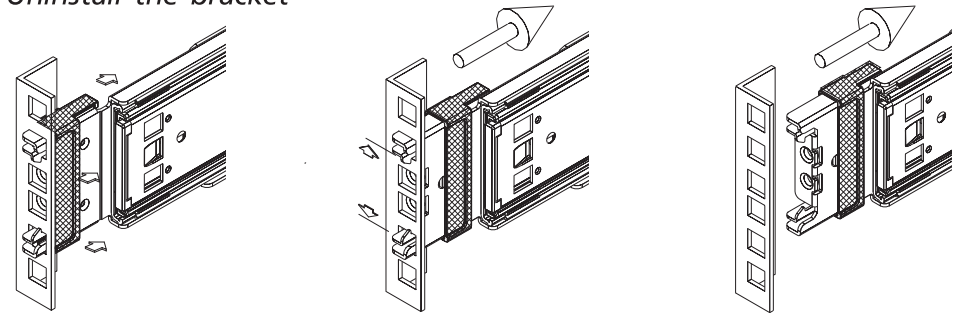

Step 4 > Mount the chassis into the cabinet

⬇ Insert the chassis (inner) member into the cabinet member as shown on the drawing. It is important to check if the ball retainer is in fully open position before install the chassis.

It might cause catastrophic damage to the chassis if ball retainer is not in fully open position while mounting the chassis. While you are pushing chassis back to the cabinet, you need to release the slide from locking position by pressing the trigger down.

*** VERY IMPORTANT – IT REQUIRES AT LEAST 2 PEOPLE TO INSTALL THE CHASSIS FOR SAFETY PUROPOSE.**

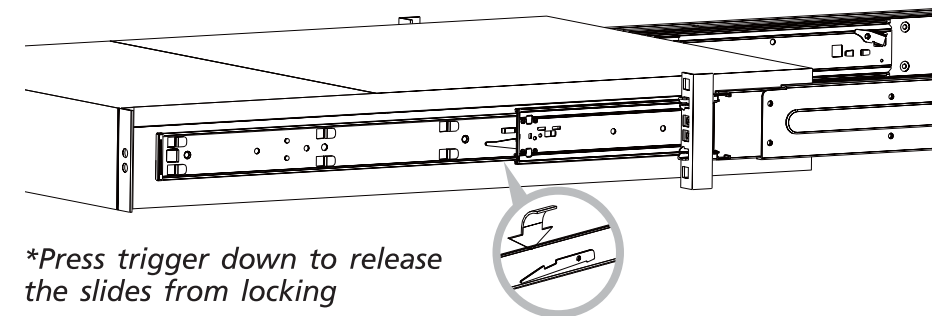
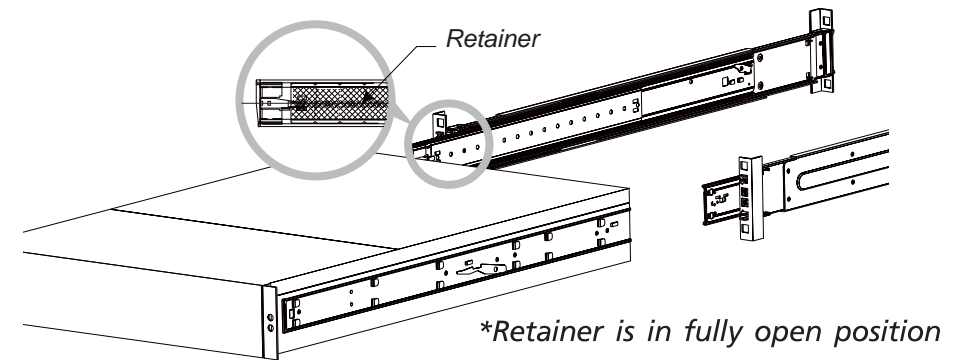

*Press trigger down to release the slides from locking