



SILVERSTONE[®]
Designing Inspiration

RA02

Rackmount ear kit for rackmountable SilverStone cases

Durable all aluminum handle grip and steel mounting plate
Pre-drilled Mounting holes ready for quick installation
High quality textured treatment finish
Ergonomically designed handle

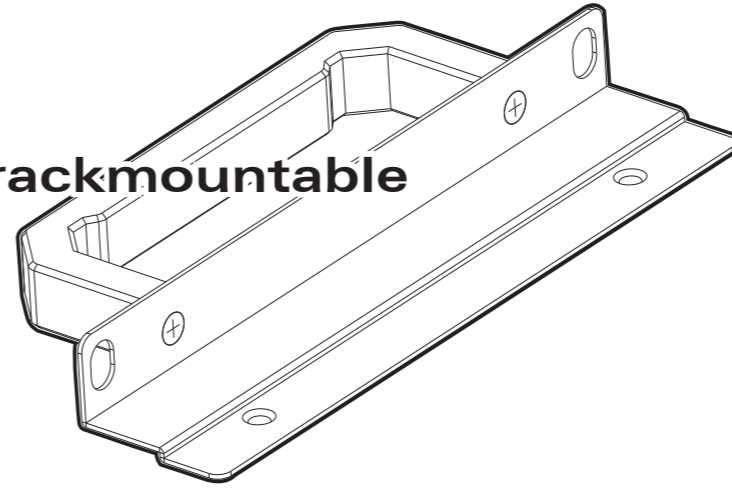

www.silverstonetek.com

Installation instruction

1. The RA02 is intended to be used in conjunction with SilverStone desktop product with rackmount mounting holes designed for the RA02. This product may not work with other cases.
2. Support: please refer to our website for the full list of supported cases.
3. The main function of the RA02 is to aid in securing your SilverStone desktop products to a rack storage, please DO NOT make RA02 as the sole supporting structure for the whole case, you should still use a rackmount tray or sliding rail to help with weight support

01



M4 screw x 4, one left support handle and one right support handle

DEUTSCH

Vier M4-Schrauben,
ein linker Stützgriff und
ein rechter Stützgriff

FRANÇAIS

Vis M4 x 4, une poignée de
support à gauche et une
poignée de support à droite

日本語

M4ネジx4、
左サポートハンドル1個、
右サポートハンドル1個

ESPAÑOL

Tornillo M4 x 4, un asa
izquierda y un asa
derecha

РУССКИЙ

4 винта M4, для левой
опорной ручки и для
правой опорной ручки

繁體中文

M4四顆螺絲與左右兩邊
的把手各一個

ITALIANO

4 viti M4, una impugnatura
di supporto sinistra ed una
impugnatura di supporto
destra

한국어

M4 나사 x 4, 왼쪽
지지 손잡이 1개 및
오른쪽 지지 손잡이
1개

簡体中文

M4四顆螺絲與左右兩邊
的把手各一個

02



Screw the handles onto the desktop

DEUTSCH

Griffe an den Desktop
schrauben

FRANÇAIS

Vissez les poignées sur le
bureau

日本語

各ハンドルをデスクトップ
ケースにネジで固定します。

ESPAÑOL

Atornille las asa al
producto de sobremesa

РУССКИЙ

Привинтит ручки к корпусу

繁體中文

將把手鎖上機殼

ITALIANO

Fissare le impugnature
al desktop

한국어

나사를 사용하여
손잡이를 데스크톱에
고정시키십시오.

簡体中文

將把手鎖上机壳

www.silverstonetek.com

For Australia only

Our goods come with guarantees that cannot be excluded under the Australian Consumer Law. You are entitled to a replacement or refund for a major failure and for compensation for any other reasonably foreseeable loss or damage. You are also entitled to have the goods repaired or replaced if the goods fail to be of acceptable quality and the failure does not amount to a major failure. Please refer to below for further warranty details. SilverStone Technology Co., Ltd. 12F No. 168 Jiansong Rd., Zhonghe Dist., New Taipei City 235 Taiwan R.O.C. +886-2-8228-1238 (standard international call charges apply)

1. Product component defects or damages resulted from defective production is covered under warranty. Defects or damages with the following conditions will be fixed or replaced under SilverStone Technology's jurisdiction.

- (a) Usage in accordance with instructions provided in this manual, with no misuse, overuse, or other inappropriate actions.
- (b) Damage not caused by natural disaster (thunder, fire, earthquake, flood, salt, wind, insect, animals, etc...)
- (c) Product is not disassembled, modified, or fixed. Components not disassembled or replaced.
- (d) Warranty mark/stickers are not removed or broken.

Loss or damages resulted from conditions other than ones listed above are not covered under warranty.

2. Under warranty, SilverStone Technology's maximum liability is limited to the current market value for the product (depreciated value, excluding shipping, handling, and other fees). SilverStone Technology is not responsible for other damages or loss associated with the use of product.

3. Under warranty, SilverStone Technology is obligated to repair or replace its defective products. Under no circumstances will SilverStone Technology be liable for damages in connection with the sale, purchase, or use including but not limited to loss of data, loss of business, loss of profits, loss of use of the product or incidental or consequential damage whether or not foreseeable and whether or not based on breach of warranty, contract or negligence, even if SilverStone Technology has been advised of the possibility of such damages.

4. Warranty covers only the original purchaser through authorized SilverStone distributors and resellers and is not transferable to a second hand purchaser

5. You must provide sales receipt or invoice with clear indication of purchase date to determine warranty eligibility.

6. Unless otherwise noted, the limited warranty detail as below

- (a) All SilverStone retail boxed power supply products (excluding power supply sold as part of a case product) come with 3 year warranty from the date of purchase.
- (b) All SilverStone retail case products that have power supply included come with 1 year warranty from the date of purchase.
- (c) All SilverStone retail storage and accessory products (excluding expendable material) come with 1 year warranty from the date of purchase.

7. If a problem develops during the Warranty Period, please contact your retailer/reseller/SilverStone authorized distributors or SilverStone <http://www.silverstonetek.com>. Please note that: (i) You must provide proof of original purchase of the Product by a dated itemized receipt; (ii) You shall bear the cost of shipping (or otherwise transporting) the Product to SilverStone authorized distributors. SilverStone authorized distributors will bear the cost of shipping (or otherwise transporting) the Product back to you after completing the warranty service; (iii) Before you send the Product, you must be issued a Return Merchandise Authorization ("RMA") number from SilverStone. Updated warranty information will be posted on SilverStone's official website. Please visit <http://www.silverstonetek.com> for the latest updates.

SilverStone Technology Co., Ltd.

www.silverstonetek.com

Issue date: October, 2012 NO: G11225641