



SILVERSTONE[®]
Designing Inspiration

ELEMENT

ST50EF-PLUS

Power through efficiency

Efficiency over 80% across all loading conditions (20% to 100%)

Industry-leading low noise operation

Dual +12V rails for advanced systems

Dual PCI-E connectors

Silent running 120mm fan

Support for ATX 12V 2.2

Active PFC

SPECIFICATION

SilverStone Element ST50EF-PLUS ATX12V 2.2 Switching Power Supply With Active PFC PS/2 500W

1. AC INPUT

1.1 AC input requirement

The input voltage, current, and frequency requirements for continuous operation are stated below.

Table 1 AC Input Line Requirements

Parameter	Min	Nom	Max	Unit
Vin(Full range)	90	100---240	265	VACrms
Vin Frequency	47		63	Hz
Iin		10-----5		Arms

Power factor correction (PF)>0.96 at full load

1.2 Inrush current regulation

50 A @ 115Vrms

100 A @ 230Vrms (at 25°C ambient cold start)

2. DC OUTPUT

2.1 DC voltage regulation

Parameter	Range	Min	Nom	Max	Unit
+3.3V	+/-3%	+3.20	+3.3	+3.40	Volts
+5V	+/-3%	+4.85	+5	+5.15	Volts
+12V1	+/-3%	+11.64	+12	+12.36	Volts
+12V2	+/-3%	+11.64	+12	+12.36	Volts
-12V	+/-10%	-10.8	-12	-13.2	Volts
+5VSB	+/-3%	+4.85	+5	+5.15	Volts

2.2 Load ranges

2.2.1 : (500 Watts Load Ratings)

Parameter	Min	Nom	Max	Peak	Unit
+3.3V	0.0	-	25.0		Amps
+5V	0.0	-	25.0		Amps
+12V1	1.0	-	18.0	19.0	Amps
+12V2	1.0	-	18.0	19.0	Amps
-12V	0.0	-	0.3		Amps
+5VSB	0.0	-	3.0	3.5	Amps

Notes:

- (1) The maximum continuous total DC outputs power shall not exceed 500W
- (2) The maximum peak total DC output power shall not exceed 520W
(Peak current may last up to 17 seconds with not more than one occurrence per minute).
- (3) The maximum continuous load on +5V and +3.3V outputs shall not exceed 150W.
- (4) The maximum combined current for the +12V outputs shall be 36A
- (5) 12V1DC and 12V2DC should have separate current limit circuits to meet 240VA safety requirements.

2.3 Output Ripple

2.3.1 Ripple regulation

Parameter	Ripple&Noise	Unit
+3.3V	50	mVp-p
+5V	50	mVp-p
+12V1	120	mVp-p
+12V2	120	mVp-p
-12V	120	mVp-p
+5VSB	50	mVp-p

2.3.2 Definition

The ripple voltage of the outputs shall be measured at the pins of the output connector when terminated in the load impedance specified in figure 1. Ripple and noise are measured at the connectors with a 0.1uF ceramic capacitor and a 10uF electrolytic capacitor to simulate system loading. Ripple shall be measured under any condition of line voltage, output load, line frequency, operation temperature.

2.3.3 Ripple voltage test circuit

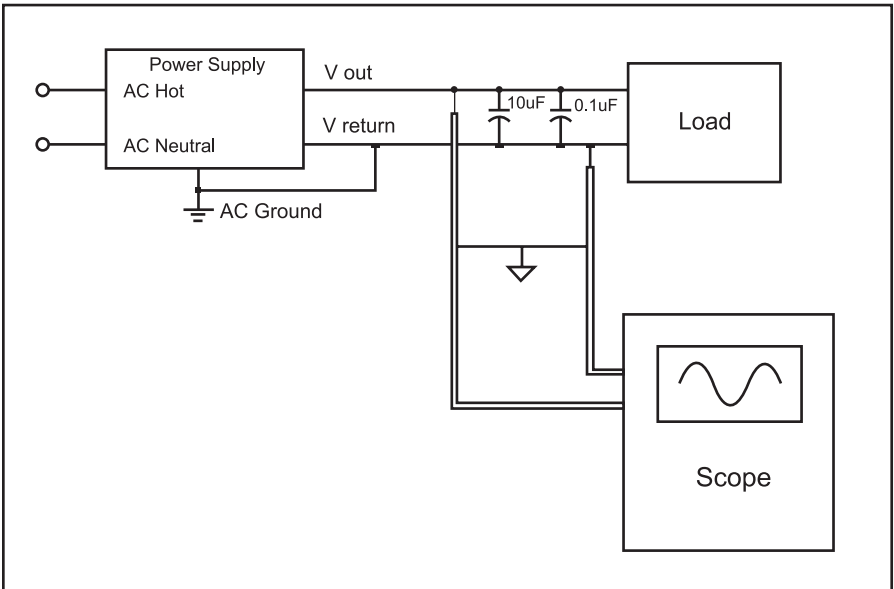

Figure 1. Ripple voltage test circuit

2.4 Overshoot

Any overshoot at turn on or turn off shall be less 10% of the nominal voltage value, all outputs shall be within the regulation limit of section 2.0 before issuing the power good signal of section 4.0.

2.5 Efficiency

Greater than 80% typical at normal AC main voltage and full load at nominal input voltage of 115Vac or 230Vac

2.6 Remote ON/OFF control

When the logic level "PS-ON" is low, the DC outputs are to be enabled.

When the logic level is high or open collector, the DC outputs are to be disabled.

3. PROTECTION

3.1 Over current protect

+5VDC, 12V1DC, +12V2DC, and +3.3VDC have separate over current protection circuits to meet 240Vac safety requirements.

3.2 Over-power protection

The power supply will be shutdown and latch off when output power within 110%~150% of rated DC output.

3.3 Over voltage protection

The over voltage sense circuitry and reference shall reside in packages that are separate and distinct from the regulator control circuitry and reference. No single point fault shall be able to cause a sustained over voltage condition on any or all outputs. The supply shall provide latch-mode over voltage protection as defined in Table.

output	Minimum	Nominal	Maximum	Unit
+12V1 VDC	-	-	15.6	Volts
+12V2 VDC	-	-	15.6	Volts
+5 VDC	-	-	7.0	Volts
+3.3 VDC	-	-	4.8	Volts

3.4 Short circuit

An output short circuit is defined as any output impedance of less than 0.1 ohms. The power supply shall shut down and latch off for shorting the +3.3 VDC, +5 VDC, or +12 VDC rails to return or any other rail. Shorts between main output rails and +5VSB shall not cause any damage to the power supply. The power supply shall either shut down and latch off or fold back for shorting the negative rails.+5VSB must be capable of being shorted indefinitely, but when the short is removed, the power supply shall recover automatically or by cycling PS_ON#. The power supply shall be capable of withstanding a continuous short-circuit to the output without damage or overstress to the unit.

3.5 No load operation

No damage or hazardous condition should occur with all the DC output connectors disconnected from the load. The power supply may latch into the shutdown state.

3.6 Under voltage protection

The under voltage sense circuitry and reference shall reside in packages that are separate and distinct from the regulator control circuitry and reference.No single point fault shall be able to cause a sustained under voltage condition on any or all outputs.The supply shall provide latch-mode under voltage protection as defined in Table.

output	Minimum	Nominal	Maximum	Unit
+12 V1DC or +12V2DC	9.5	10.0	10.5	Volts
+5 VDC	4.1	4.3	4.47	Volts
+3.3 VDC	2.55	2.69	2.83	Volts

4. TIMING

4.1 Signal timing drawing

Figure 2. is a reference for signal timing for main power connector signals and rails.

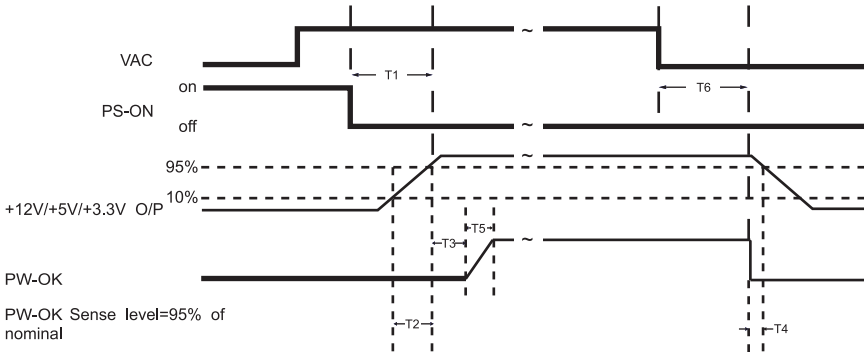

Figure 2. PS-OK Timing Sequence

- (1)T2: Rise time (0.1ms~20ms)
- (2)T3: Power good signal turn on delay time (100ms~500ms)
- (3)T4: Power good signal turn off delay time (1ms min)
- (4)T5: Rise time (10ms max)

4.2 Hold up time

When the power loss its input power, it shall maintain 16ms in regulation limit at normal input voltage (AC:115V/60Hz or 230V/50Hz)

5. ENVIRONMENT

5.1 Operation

Temperature	0 to 50°C
Relative Humidity	20 to 85%, non-condensing

5.2 Shipping and Storage

Temperature	-40 to 70°C
Relative Humidity	5 to 90%, non-condensing

5.3 Altitude

Operating	3,000FT max.
Storage	15,000FT max.

6. SAFETY

6.1 Underwriters Laboratory (UL) recognition.
The power supply is designed to meet UL 60950-1.

6.2 The power supply must bear the German Bauart Mark from TUV EN60950-1.

7. ELECTROMAGNETIC COMPATIBILITY (EMC)

7.1 Electrostatic Discharge (ESD) - EN 61000 - 4 - 2 : 1995

7.2 Electrical Fast Transient/Burst (EFT/B) - EN 61000 - 4 - 4 : 1995

7.3 Surge - EN 61000 - 4 - 5 : 1995

7.4 Power Frequency Magnetic Field - EN 61000 - 4 - 8 : 1993

7.5 Voltage Dips - RN 61000 - 4 - 11 : 1994

7.6 Radiated Susceptibility - EN 61000 - 4 - 3 : 1996

7.7 Conducted Susceptibility - EN 61000 - 4 - 6 : 1996

7.8 Voltage Fluctuation - EN 61000 - 3 - 3 : 1995

7.9 EN61000-3-2:2000 harmonic current emissions.

If applicable to sales in Europe, the power supply shall meet the requirements of EN 61000-3-2 class D and the guidelines for the suppression of harmonics in appliances and general use equipment class D for harmonic line current content at full-rated power.

7.10 EN55022 Class B Radio interference (CISPR 22).

7.11 FCC Part 15, Subpart J class B 115Vac operation.

8. MTBF

8.1 MTBF (mean time between failures) calculation

The demonstrated MTBF shall be 100,000 hours of continuous operation at 25°C, full load, 80% confidence limit and nominal line. The MTBF of the power supply be calculated in accordance with MIL-STD-217 D / E. The DC FAN is not included.

9. MECHANICAL REQUIREMENTS

9.1 Physical dimension

150 x 86 x 140 mm (W x H x D)

9.3 Pin definition

M/B 24PIN connector

18AWG wire	Signal	Pin	Pin	Signal	18AWG wire
Orange	+3.3V	11	1	+3.3V	Orange
Orange(22AWG)	+3.3 sense	11			
Blue (18AWG)	-12VDC	12	2	+3.3V	Orange
Black	COM	13	3	COM	Black
Green(20AWG)	PS-ON	14	4	+5VDC	Red(20AWG)
Black	COM	15	5	COM	Black
Black	COM	16	6	+5VDC	Red
Black	COM	17	7	COM	Black
White	NC	18	8	POK	Grey (20AWG)
Red	+5VDC	19	9	+5VSB	Purple(20AWG)
Red	+5VDC	20	10	+12V1DC	Yellow
Red	+5VDC	J3	J1	+12V1DC	Yellow
Black	COM	J4	J2	+3.3VDC	Orange

ATX 12V 4PIN Connector

18 AWG wire	Signal	Pin	Pin	Signal	16AWG wire
Black	COM	B1	B3	+12V1DC	Yellow
Black	COM	B2	B4	+12V1DC	Yellow
Black	COM	A1	A3	+12V2DC	Yellow/Black stripe
Black	COM	A2	A4	+12V2DC	Yellow/Black stripe

4PIN molex connector (HDD)

4PIN floppy connector (FDD)

18 AWG wire	Signal	Pin	Pin	Signal	22AWG wire
Red	+5VDC	1	1	+12V1	Yellow
Black	COM	2	2	COM	Black
Black	COM	3	3	COM	Black
Yellow	+12V1	4	4	+5VDC	Red

SATA connector

18 AWG wire	Signal	Pin
Orange	+3.3V	5
Black	GND	4
Red	+5V	3
Black	GND	2
Yellow	+12V1	1

6PIN PCI Express Connector 1

18AWG wire	Signal	Pin	Pin	Signal	18AWG wire
Yellow	+12V1	1	4	GND	Black
Yellow	+12V1	2	5	GND	Black
Yellow	+12V1	3	6	GND	Black

6PIN PCI Express Connector 2

18AWG wire	Signal	Pin	Pin	Signal	18AWG wire
Yellow	+12V2	1	4	GND	Black
Yellow	+12V2	2	5	GND	Black
Yellow	+12V2	3	6	GND	Black

10. FAN SPEED CONTROL

Fan voltage varies with the ambient temperature or output power.



To be valid, this sheet must be filled out by
your salesperson at the time of purchase.

Store :

Purchaser :

Purchase date :

Model No. :

Serial No. :

SILVERSTONE

SilverStone Technology Co., Ltd.

www.silverstonetek.com

support@silverstonetek.com

Issue date: June , 2006